

 **KTH SW-2**  
**AUTOMATIC DOOR SYSTEM**

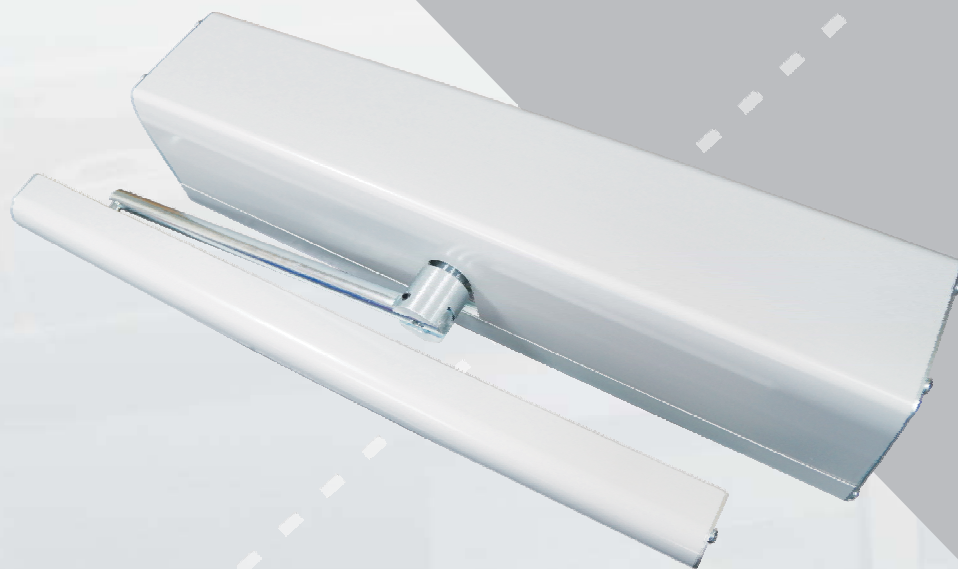
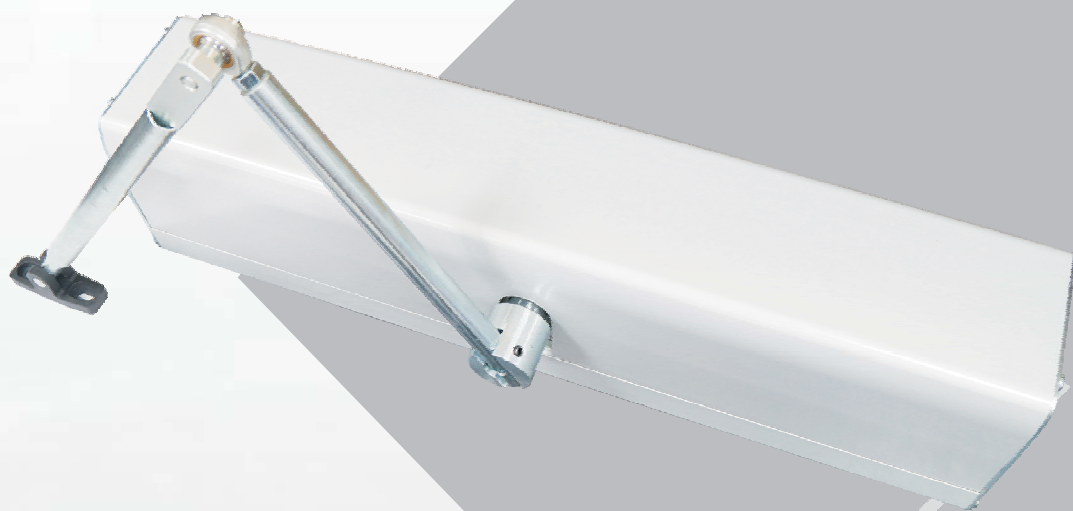

# TABLE OF CONTENTS

1.SPECIFICATION.....	1
2.OPERATOR (SECTION).....	2
3.(OUTWARD OPENING) PUSH ARM ASSEMBLY MOUNTING (INWARD OPENING) PULL ARM ASSEMBLY MOUNTING...	3
4.LEGEND OF PART DRAWING.....	4
5. NORMAL	
5-1.ADJUST BOARD INSTRUCTION .....	5
5-2.CONNECTION TO TERMINAL BLOCK.....	6
5-3.DOUBLE DOOR AND MASTER/SLAVE FUNCTION .....	7
5-4.INTERLOCK, ELECTRONIC LOCK MASTER/SLAVE FUNCTION .....	8
6. EN16005	
6-1.ADJUST BOARD INSTRUCTION.....	9 & 10
6-2.CONNECTION-ACTIVATION AND LOCKS.....	11
6-3.CONNECTION-SAFETY.....	12
6-4.DOUBLE DOOR AND MASTER/SLAVEFUNCTION .....	13

## 1 SPECIFICATION

<b>MODEL</b>	<b>SW-2</b>	
<b>TYPE</b>	OUTWARD OPENING	INWARD OPENING
<b>MOTOR</b>	DC24V 120W BRUSHLESS DC MOTOR	
<b>CONTROL</b>	USER-FRIENDLY MICRO-CONTROLLER	
POWER CONSUMPTION	120W	
<b>VOTAGE</b>	AC100V~240V	
ENVIRONMENTAL TEMPERATURE	-20°C~+50°C	
<b>VOLUME</b>	55 decibel(max.)	
SPEED of OPENING 90 DEGREE	3~8 sec. /90° ( max.)	
<b>STARTING TIME</b>	0~20 sec. (Regulable)	
TRANSMISSION IMPORTANT CONDITION	PUSH ARM ASSEMBLY	PULL ARM ASSEMBLY
OPENING DOOR RANGE	120°(Max. )/90°(default)	
<b>POWER EFFICIENCY</b>	0.95 (In full load)	
<b>TRACTION FORCE</b>	2.5 kg	

## 2 OPERATOR (SECTION)

Front View

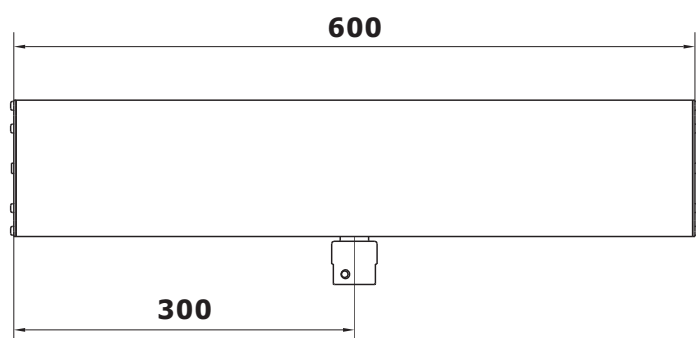

Side View

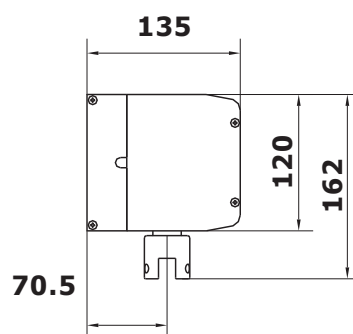

Base Size

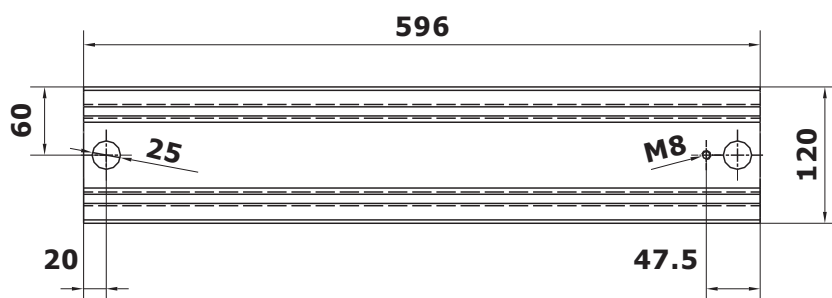

Every set of operator can use the Inward / Outward Arm assembly.

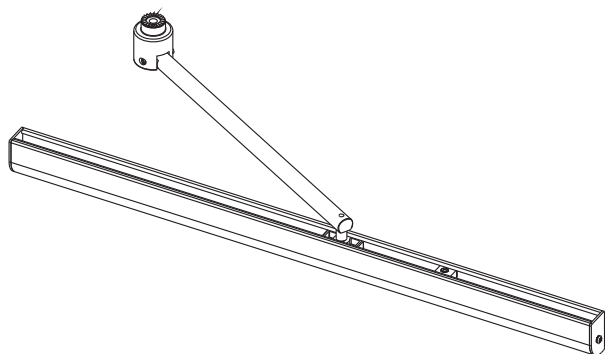

( Inward Opening )  
Pull Arm assembly

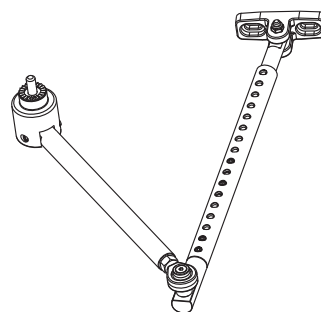

( Outward Opening )  
Push Arm assembly

### 3 (OUTWARD OPENING) PUSH ARM ASSEMBLY MOUNTING

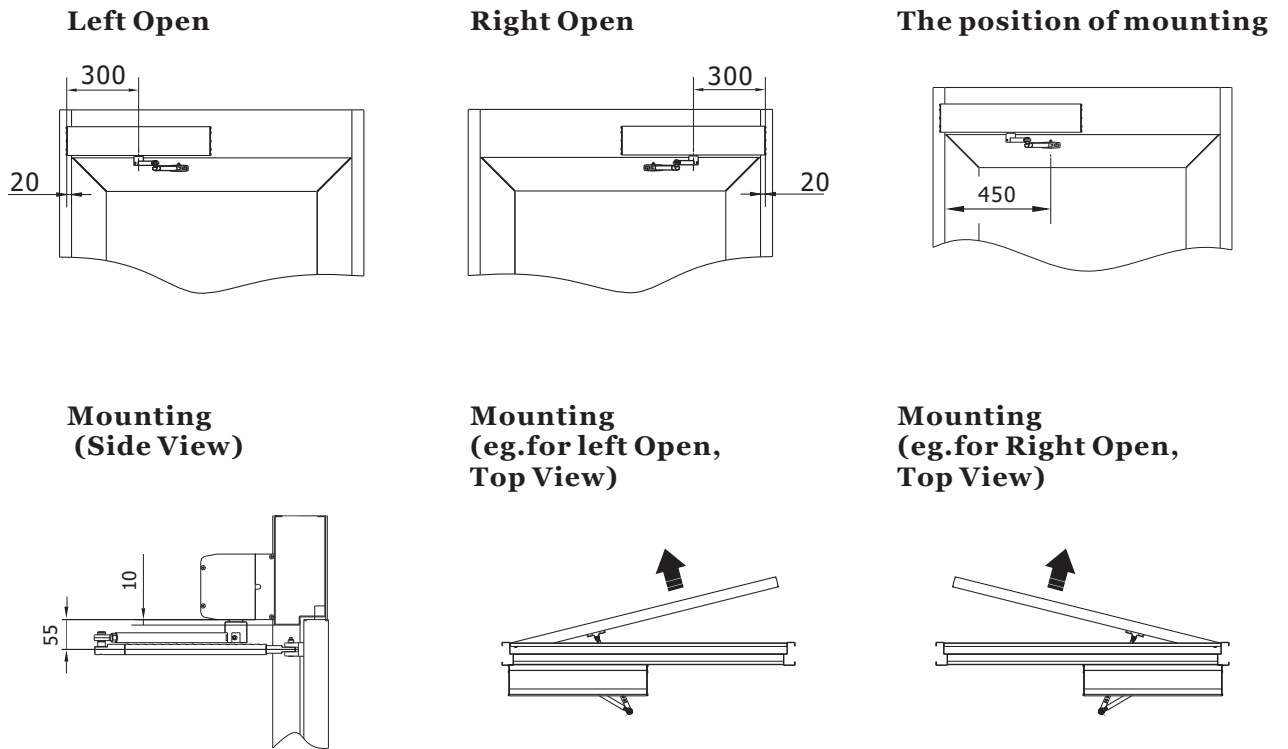

### ■ (INWARD OPENING) PULL ARM ASSEMBLY MOUNTING

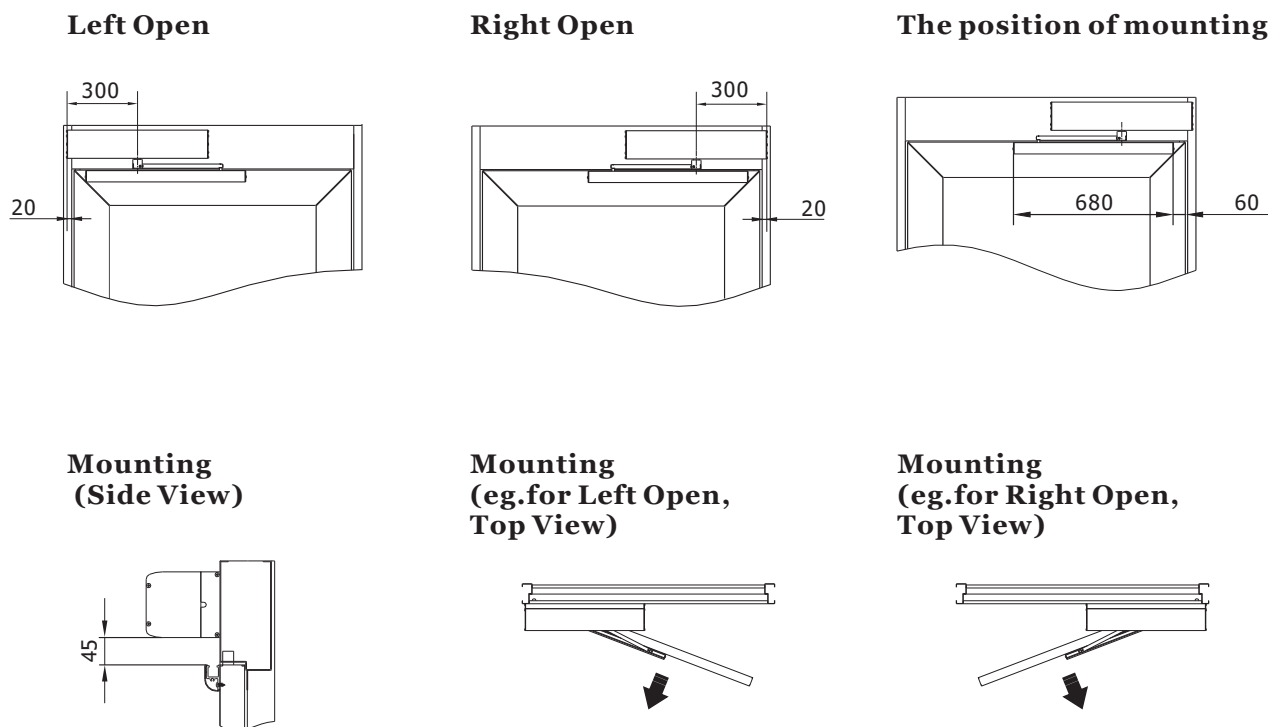

## 4 LEGEND OF PART DRAWING (NORMAL)

Parts List		
No.	Parts Name	Quantity
1	Case (Base)	1
2	Case (Base)	1
3	Left Side end cap	1
4	Right Side end cap	1
5	Motor	1
6	Controller	1
7	Power switch	1

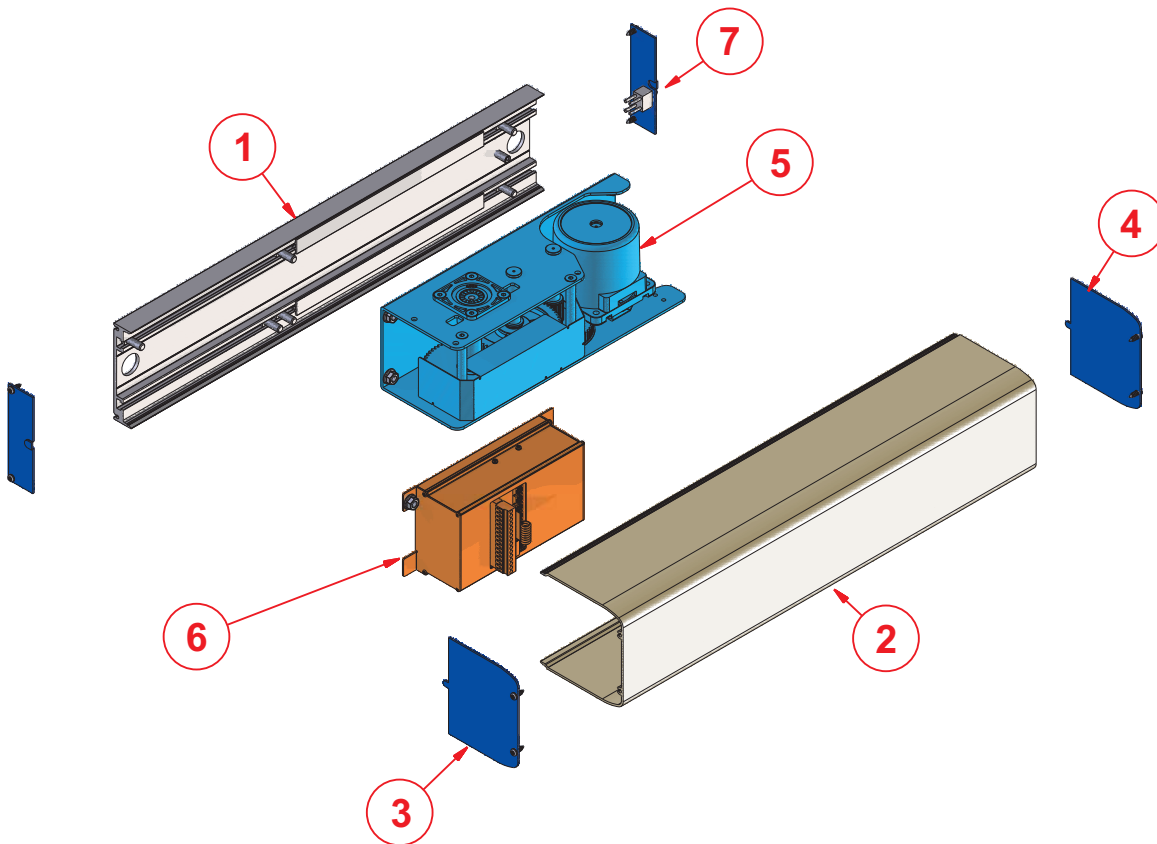

## 5-1 ADJUST BOARD INSTRUCTION (NORMAL)

Yellow  Opening Testing

Green  Signal input

Red  Power on

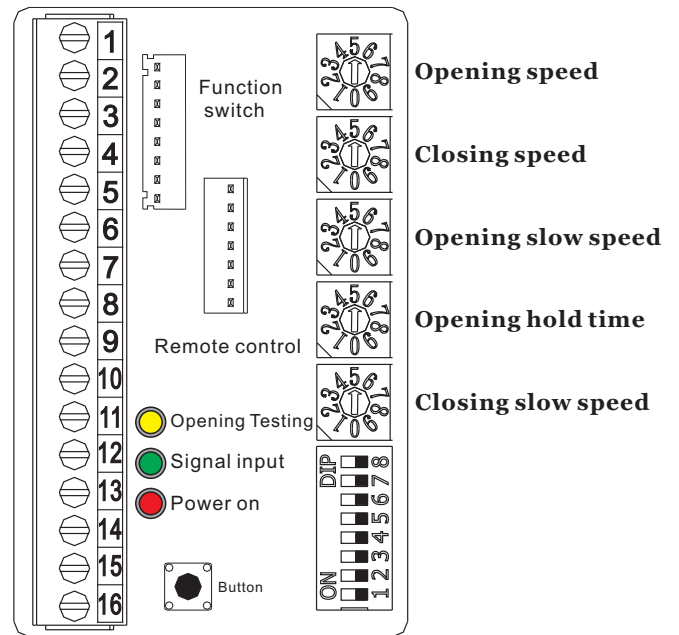

Fingered switch functions		
8	OFF	Reverse Switch (Normal mode)
	ON	Reverse Switch (Security System)
7	OFF	Fail-safe (lock, NC.)
	ON	Fail-secure (lock, NO.) <sup>①</sup>
6	OFF	Set to slave-OFF
	ON	Set to slave-ON
5	OFF	Set to Master- OFF
	ON	Set to Master- ON
4	OFF	Directional Function- OFF
	ON	Directional Function- ON
3	OFF	Brake power-Large
	ON	Brake power-Little
2	OFF	Brake power -ON (over 50 KG.)
	ON	Brake power -OFF (under 50 KG.)
1	OFF	Opening direction-Left
	ON	Opening direction-Right

Note: <sup>①</sup> Power to unlock (only continue 5 seconds)

( Fingered switch functions )

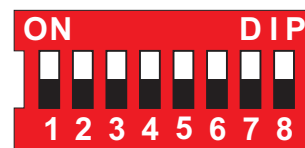

**ATTENTION:**  
When only use 1 unit operator,  
the pin 5 and pin 6 must set to off state.

## 5-2 CONNECTION TO TERMINAL BLOCK (NORMAL)

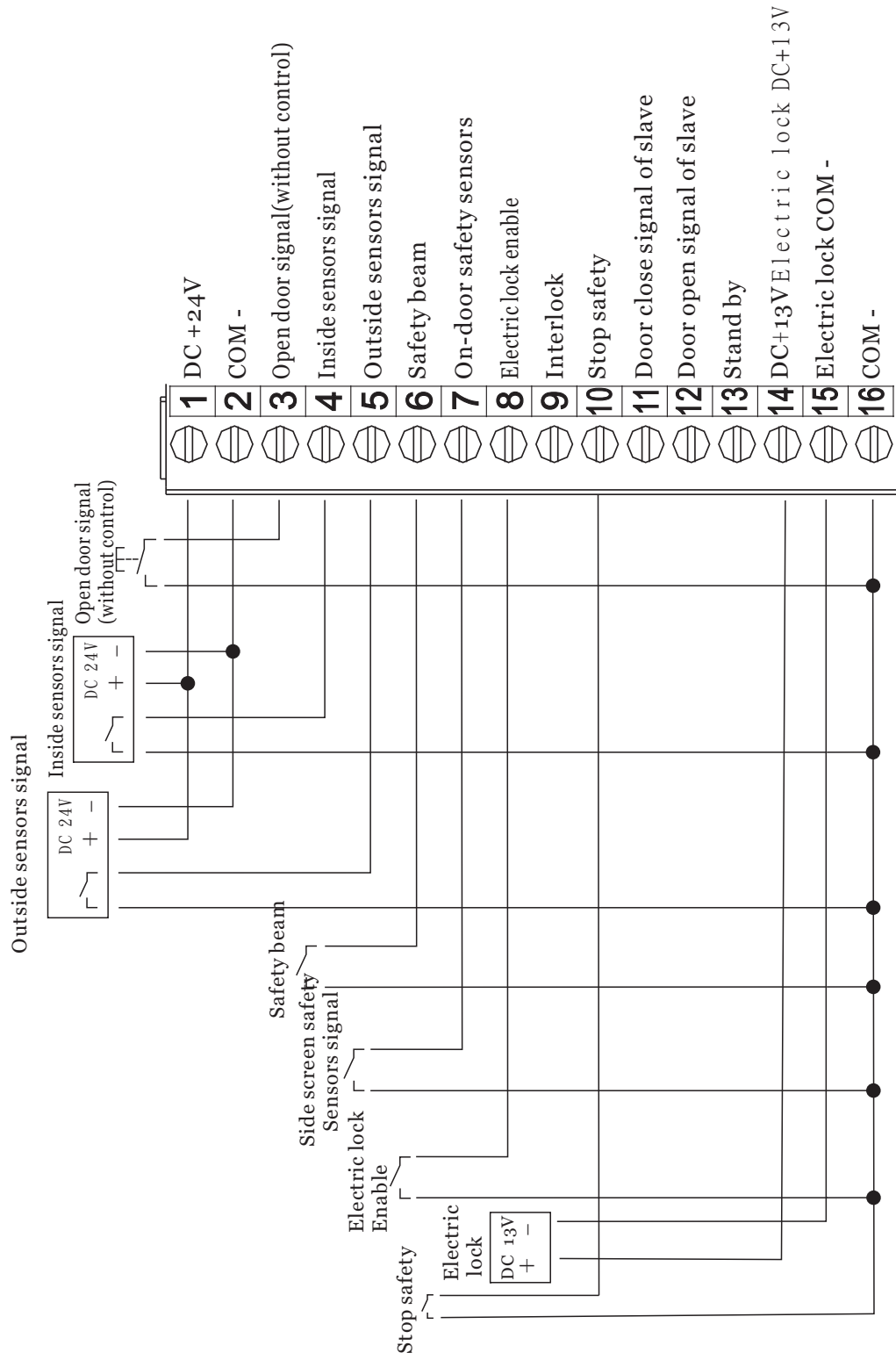

When connect to electronic lock, the reverse switch will be connected too: after power resumes, the Door-leaf closes the door first.



**5-3 DOUBLE DOOR AND MASTER/SLAVE FUNCTION (NORMAL)**

**Double Door (I)**

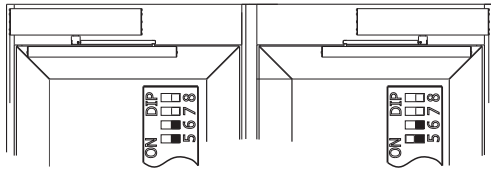

Please set all door ( 5 Off, 6 Off ).

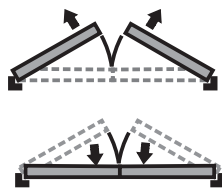

Open door signal (without control)

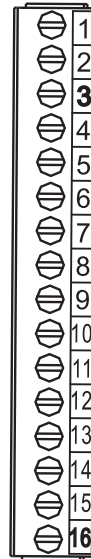

Open door signal (without control)

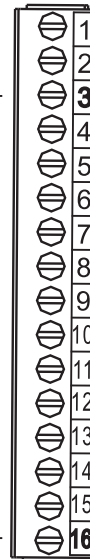

COM

COM

**Double Door (II) With Electronic Lock and Master/Slave Function**

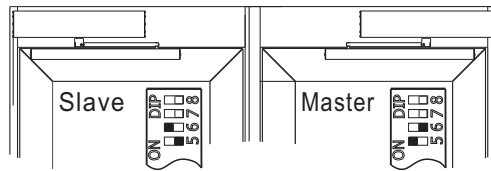

Please set the door which closes first to master (5 on, 6 off) then set the second to close to slave (5 off, 6 on).

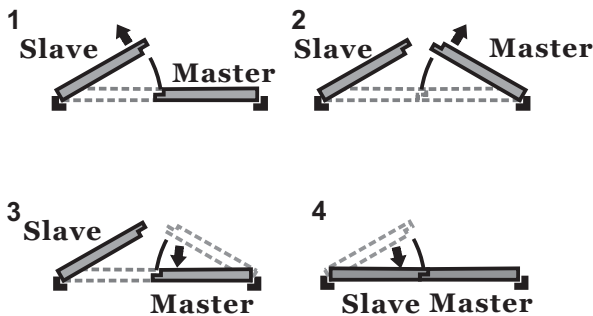

Open door signal (without control)

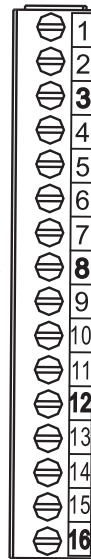

Electronic lock enable

Control slave to open

Close door signal of slave

Control slave to open

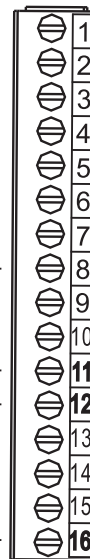

COM

Slave

Master

**Double Doors with Interlock, Electronic lock, Master/Slave Function**

**1st of Double Door**

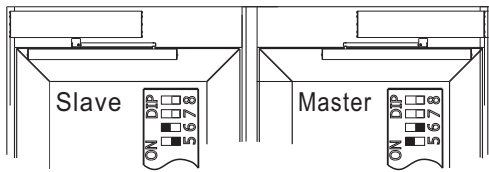

**Please set the door which closes first to master(5 on, 6 off) then set the second to close to slave(5 off, 6 on).**

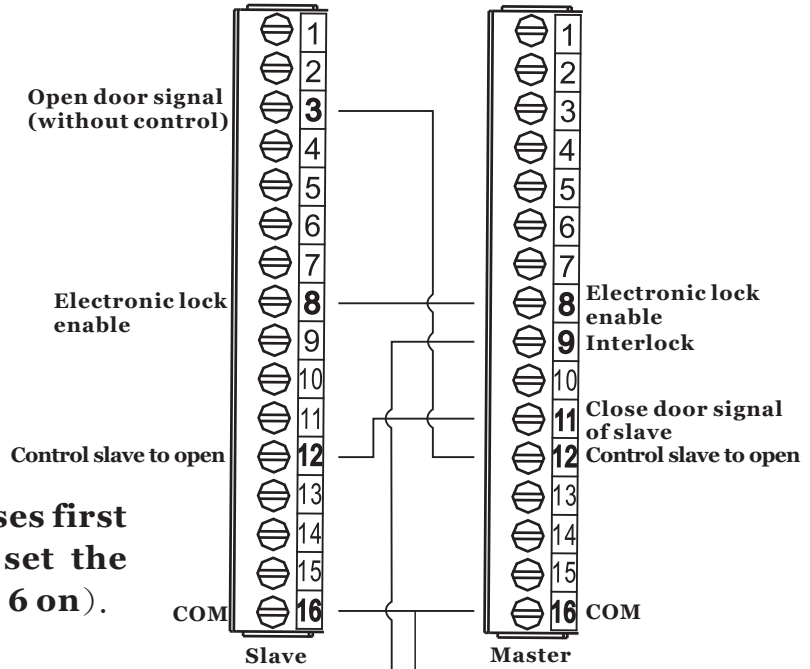

**2nd of Double Door**

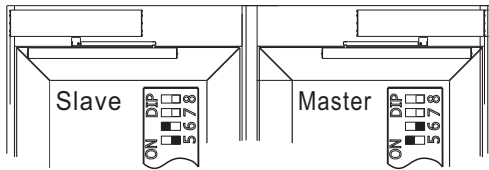

**Please set the door which closes first to master(5 on, 6 off) then set the second to close to slave(5 off, 6 on).**

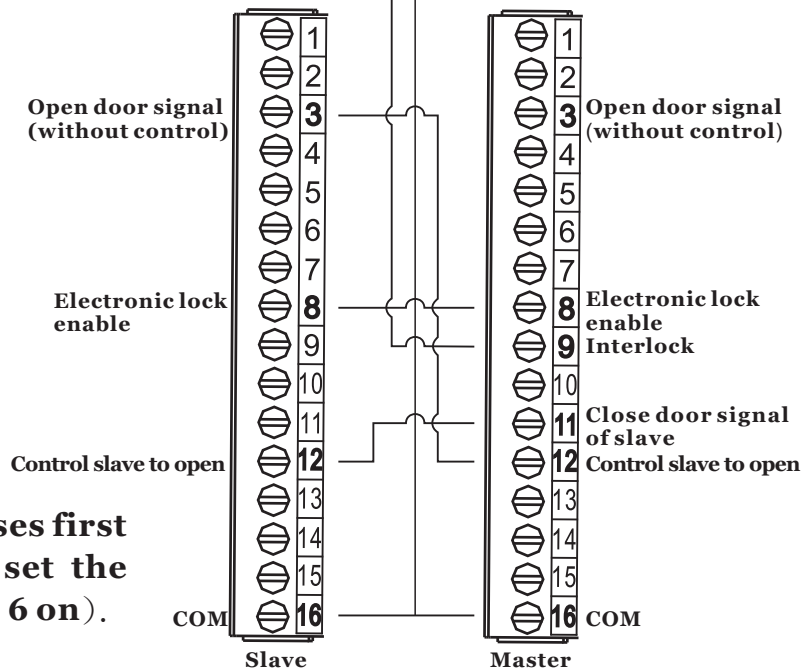

# 6-1 ADJUST BOARD INSTRUCTION (EN16005)

- 

**K1 Opening Speed**  
Adjust the OPENING SPEED. Higher number, faster speed.  
CAUTION: please adjust the number one by one from **low to high**.
- 

**K2 Closing Speed**  
Adjust the CLOSING SPEED. Higher number, faster speed.  
CAUTION: please adjust the number one by one from **low to high**.
- 

**K3 Slowing Speed of Opening Door**  
Adjust the SLOWING SPEED OF OPENING DOOR. Higher number, greater strength.  
CAUTION: please adjust the number one by one from **high to low**.
- 

**K4 Slowing Speed of Closing Door**  
Adjust the SLOWING SPEED OF CLOSING DOOR. Higher number, greater strength.  
CAUTION: please adjust the number one by one from **high to low**.
- 

**K5 Opening hold time**  
Adjust the HOLD OPEN TIME. Higher number, the hold time is longer.

NUMBER	0	1	2	3	4	5	6	7	8	9
SECOND	0	1	2	3	5	10	15	20	60	120
- 

**K6 Sensitivity of Collision Detection**  
Adjust the sensitivity of reaction to obstacle during door is working, less number, higher sensitivity.  
CAUTION: please adjust the number one by one from **low to high**.
- 

**K7 Brake Power**  
Adjust Door-Leaf BRAKE POWER. Higher number, more Brake power
- 

**K8 "Non-detect angle" for safety sensor**

NUMBER	0	1	2	3	4	5	6	7	8	9
ANGLE	Desable	4/90°	8/90°	12/90°	16/90°	20/90°	24/90°	28/90°	32/90°	36/90°

Yellow LED : Opening Testing  
Green LED : Signal input.  
Red LED : Power on.

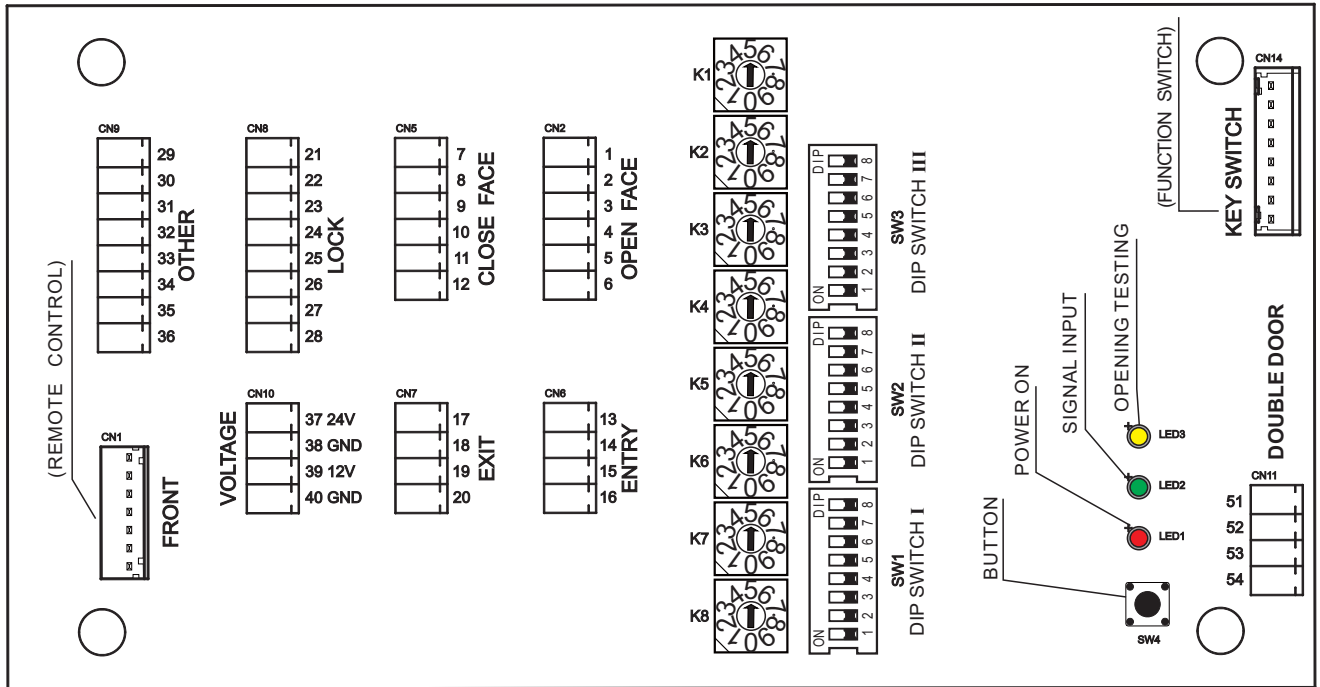

**DIP Switch I**

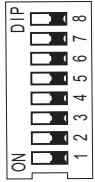

**1 L/R Switch**  
 Right  Left

**2 Brake power switch**  
 OFF  ON

**3 SLAVE postpone angle range**  
 Little  Large  
 \*Please ref. to P13

**4 Directional function**  
 OFF  ON  
 OFF: Normal mode.  
 ON: Push once, open the door.  
 Push again, close the door.

**5 MASTER/SLAVE setting**  
 Master  Slave

**6 Electric lock type setting**  
 Normal  Spring Latch

**7 Reset/learn setting**  
 Reset  learn

**8 Reverse Switch:**  
 in order to control opening and closing direction of the Door-Leaf after power resumes.  
 OFF  ON  
 OFF: Normal mode, after power resumes, the Door-Leaf opens the door first.  
 ON: suitable for Security System, after power resumes the Door-Leaf closes the door first.

**DIP Switch II**

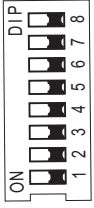

**1 Open Face Safety**  
 N.O  N.C

**2 Open Face Safety Test**  
 No  Yes

**3 Open Face Safety Type**  
 Stop  Slowly

**4 Closing Face Safety**  
 N.O  N.C

**5 Closing Face Safety Test**  
 No  Yes

**6 Entry Sensor**  
 N.O  N.C

**7 Exit Sensor**  
 N.O  N.C

**8 Emergency stop**  
 N.O  N.C

**DIP Switch III**



**1 Open**  
 N.O  N.C

**2 Fire Alarm**  
 N.O  N.C

**3 Fire Alarm Type**  
 Open  Close

**4 ~ 8 Standby**

**6-2 CONNATION-ACTIVATION AND LOCKS (EN16005)**

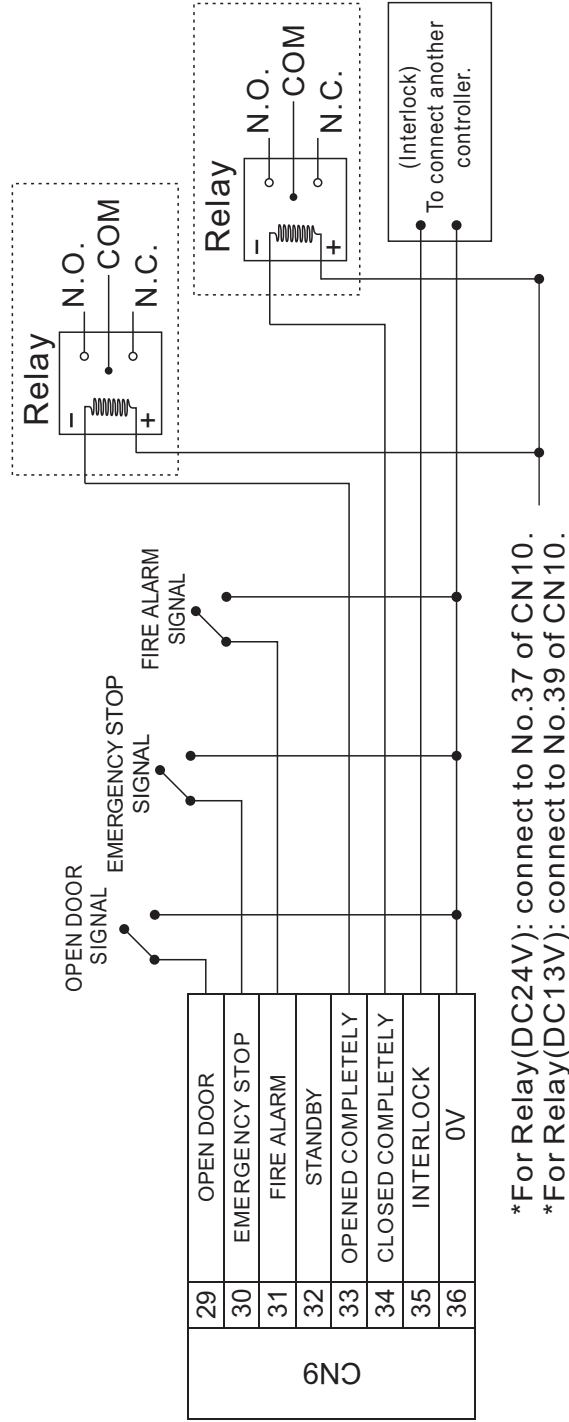

**Warning**

- \*Relay it should be with built in diode.
- \*Relay Suggested model: OMRON MY2N-D2-J (it's arranged by customers)

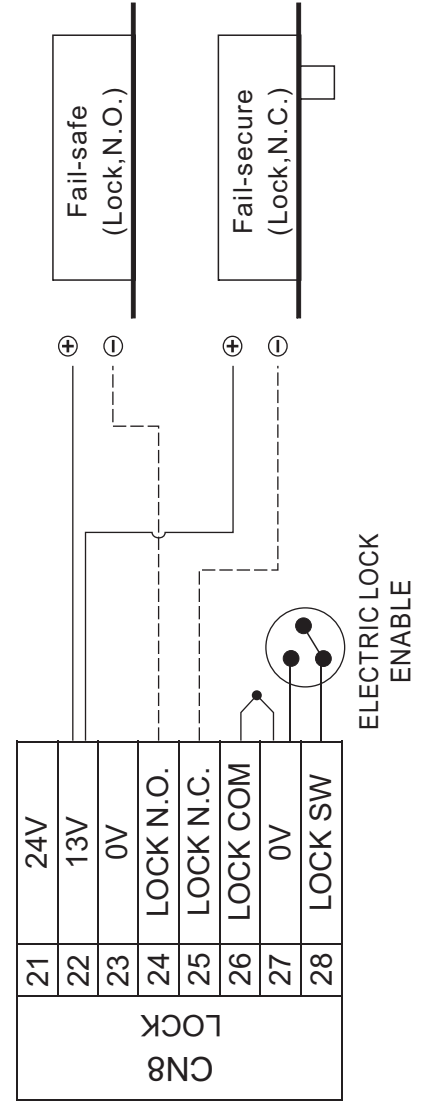

## 6-3 CONNATION - SAFETY (EN16005)

### ENTRY SENSOR ACTIVATION

CN6			
13	14	15	16
24V	COM	COM	N.O

+	-	COM	N.O
---	---	-----	-----

HR50

### EXIT SENSOR ACTIVATION

CN7			
17	18	19	20
24V	COM	COM	N.O

+	-	COM	N.O
---	---	-----	-----

HR50

### PREMIER SWING ONDOOR SAFETY (NOT MONITORED)

CN2					
1	2	3	4	5	6
24V	COM	COM	ACT	TEST-	TEST+

POW	POW	COM	N.C	TEST-	TEST+
1	2	3	5	6	7

HOTRON SSS-5

CN5					
7	8	9	10	11	12
24V	COM	COM	ACT	TEST-	TEST+

POW	POW	COM	N.C	TEST-	TEST+
1	2	3	5	6	7

HOTRON SSS-5

### OPEN FACE SAFETY (TOPSCAN)

CONTROLLER PANEL  
DIP Switch II No.1 → "ON"  
SSS-5  
DIP Switch No.1 → "B"  
No.3 → "N.C"

### CLOSE FACE SAFETY (TOPSCAN)

CONTROLLER PANEL  
DIP Switch II No.4 → "ON"  
SSS-5  
DIP Switch No.1 → "B"  
No.3 → "N.C"

### PREMIER SWING ONDOOR SAFETY (MONITORED)

CN2					
1	2	3	4	5	6
24V	COM	COM	ACT	TEST-	TEST+

POW	POW	COM	N.C	TEST-	TEST+
1	2	3	5	6	7

HOTRON SSS-5

CN5					
7	8	9	10	11	12
24V	COM	COM	ACT	TEST-	TEST+

POW	POW	COM	N.C	TEST-	TEST+
1	2	3	5	6	7

HOTRON SSS-5

### OPEN FACE SAFETY (TOPSCAN)

CONTROLLER PANEL  
DIP Switch II No.1 → "ON"  
No.2 → "ON"  
SSS-5  
DIP Switch No.1 → "A"  
No.3 → "N.C"

### CLOSE FACE SAFETY (TOPSCAN)

CONTROLLER PANEL  
DIP Switch II No.4 → "ON"  
No.5 → "ON"  
SSS-5  
DIP Switch No.1 → "A"  
No.3 → "N.C"

**6-4 DOUBLE DOOR AND MASTER/SLAVE FUNCTION (EN16005)**

**A. Double Door**

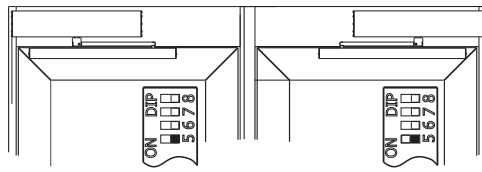

Please set all door DIP Switch I No.5 Off.

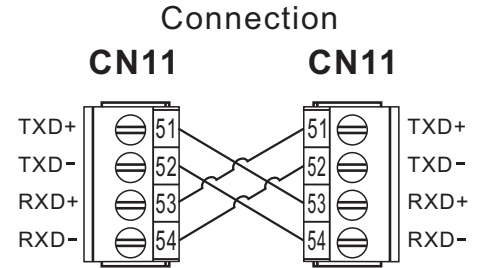

After connecting to terminals, yellow LED flashes to indicate connecting properly. The door leaves will open and close at the same time.

**B. Double Door**

M/S

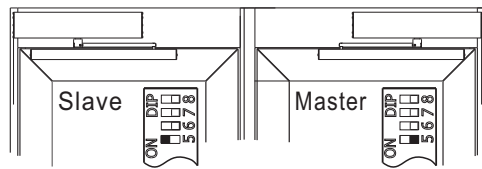

Please set the door which closes first to master (DIP Switch I → No.5 Off), then set the second to close to slave (DIP Switch I → No.5 On).

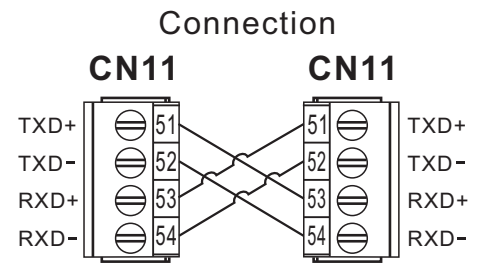

Slave

Master

After connecting to terminals, yellow LED flashes to indicate connecting properly.

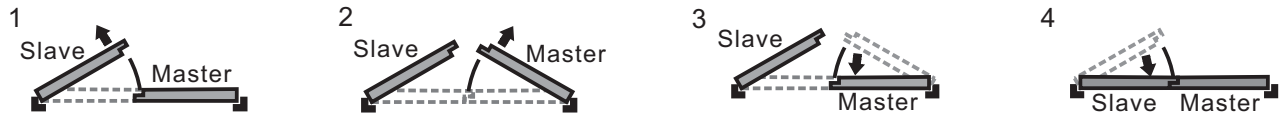

⊗ Before turn on the power, please inspect the relative positions of the door leaves to avoid error occurs. Please turn on “Master” and “Slaver” at the same time to avoid the time different causes the error.

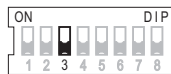

**DIP Switch I**

**SLAVE postpone angle range**

When MASTER door is closing in order to avoid the SLAVE door hit it, installer can set the range to postpone the position to SLAVE.

Setting  Little

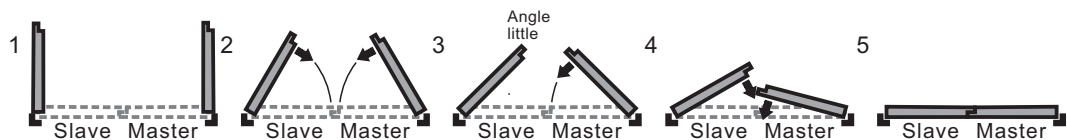

Setting  Large

